

Chemistry 1B

General Chemistry

Laboratory Manual

Fall 2018

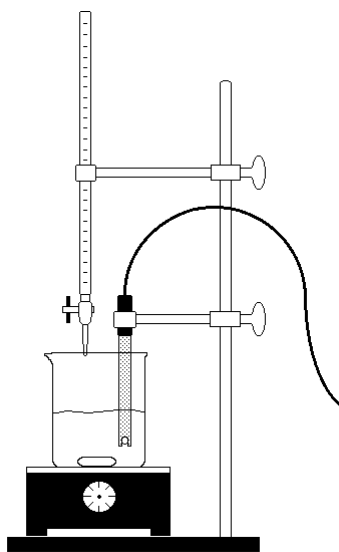

Table of Contents

Laboratory Policies	Error! Bookmark not defined.
Safety Contract	Error! Bookmark not defined.
Laboratory Regulations.....	4
Laboratory Notebook Requirements.....	8
Prelaboratory Assignment	10
How to Write a Lab Report for Chem 1B	11
Nomenclature of Acids, Bases and Salts Review:.....	14
I. Binary Compounds.....	14
II. Ternary Compounds.....	15
Experiment 1	18
Experiment 2	Error! Bookmark not defined.
Experiment 3	Error! Bookmark not defined.
Experiment 4	Error! Bookmark not defined.
Experiment 5	Error! Bookmark not defined.
Experiment 6A.....	Error! Bookmark not defined.
Experiment 6B.....	Error! Bookmark not defined.
Experiment 7	Error! Bookmark not defined.
Experiment 8	Error! Bookmark not defined.
Experiment 9	Error! Bookmark not defined.
Experiment 10	Error! Bookmark not defined.
Practice with Balancing Redox Reactions.....	Error! Bookmark not defined.
Experiment 11	Error! Bookmark not defined.
Experiment 12	Error! Bookmark not defined.
Experiment 13	Error! Bookmark not defined.
Experiment 14	Error! Bookmark not defined.
Experiment 15	Error! Bookmark not defined.
Experiment 16	Error! Bookmark not defined.
Appendix 1	Error! Bookmark not defined.
Nomenclature Review Problems	Error! Bookmark not defined.
Appendix 2	Error! Bookmark not defined.

Practice with Balancing Redox Reactions.....	Error! Bookmark not defined.
Appendix 3	Error! Bookmark not defined.
Typing Special Characters and Equations with MS Office Word	Error! Bookmark not defined.
Appendix 4	Error! Bookmark not defined.
Simple plots on EXCEL.....	255
Appendix 5	Error! Bookmark not defined.
Appendix 6	Error! Bookmark not defined.
Monoprotic Acid Determination from Titration Curve	Error! Bookmark not defined.

California State University, Sacramento
Department of Chemistry

Student Laboratory Policies-Updated Fall 2018

a. **RESPONSIBILITIES**

It is the student's responsibility to use the information provided by your faculty instructor, graduate assistant, or room supervisor, to know exactly which chemicals you are using, know how to safely handle those chemicals, how to use personal protective equipment as necessary, and know what to do in the event of a spill or accident.

b. **SAFETY**

- V. Familiarize yourself with the location and use of all safety equipment and emergency exits in the laboratory.
- VI. Eating and drinking are not allowed in the laboratory at any time.
- VII. Visitors are not allowed in the laboratory.
- VIII. Long hair presents a serious fire hazard in the laboratory and must be properly restrained to minimize this hazard.
- IX. You must attend the lab section you are registered in. Make-up labs in an alternate section requires written approval from both instructors.
- X. Students in lower and upper division laboratories are not to work in the laboratory unless an instructor or supervisor is in the room or adjoining room.
- XI. Experiments using utilities such as gas, water, steam, heat, etc. are not to be left unattended. If it is necessary to use these utilities overnight, you must attach a card signed by your instructor to the apparatus and notify the Chemistry Service Center.
- XII. Broken glassware must be placed in the "glass disposal boxes" provided.
- XIII. Unauthorized experimentation is prohibited!
- XIV. **NO CHEMICALS, SUPPLIES, OR EQUIPMENT ARE TO BE REMOVED FROM THE LABORATORY WITHOUT THE WRITTEN PERMISSION OF THE INSTRUCTOR AND THE SERVICE CENTER SUPERVISOR.**

c. **PERSONAL PROTECTIVE EQUIPMENT (PPE)**



You are required to purchase and wear personal protective equipment that meets the following standards. Failure to comply will result in your removal from the laboratory.

9. WHEN LAB IS IN PROGRESS - YOU MUST:

- i. Wear department approved safety goggles at all times when in lab. Shields are never allowed! Contact lenses are not recommended.
- ii. Wear shoes that completely cover your foot to the ankle.
- iii. Wear long pants or a skirt that reaches your shoes. **No skin may be visible on legs or ankles.**
- iv. Wear a lab coat that reaches approximately mid-thigh and has long sleeves.
- v. Wear nitrile gloves when working with chemicals. They must be removed prior to leaving the lab. (The stockroom will not provide gloves to students.)

d. **CHEMICALS**

- 1. Treat all chemicals in the laboratory as if they were hazardous. It is the student's responsibility to know the hazards of chemicals used in the lab. This information is located in the chemical's Safety Data Sheet (SDS), which can be obtained online.
- 2. Strict adherence to PPE requirements and the use of laboratory fume hoods will significantly reduce your risk of exposure. Chemicals containers are labelled with the name of the chemical and a symbol which indicates the hazard. Chemicals that are particularly hazardous are identified by the following symbols:

- i.  Reproductive hazard, carcinogen, mutagen or respiratory sensitizer
- ii.  Acutely toxic

3. Students who are concerned about reproductive health issues (including pregnancy) or pre-existing health conditions should carefully determine, upon consultation with their personal physician or Sacramento State Student Health and Counseling, whether it is advisable for them to participate in the laboratory program. A list of chemicals used in the laboratory is available upon request and you should share this information with your physician so they can provide appropriate recommendations.
4. Never put chemical waste down drains or in the trash receptacles unless directed by your instructor. Use appropriately labeled waste containers.
5. If a chemical waste container is almost full, immediately notify your instructor or the Service Center; **DO NOT OVERFLOW THE WASTE CONTAINER!**
6. Never put anything (i.e. spatulas, pipets, etc.) into a reagent bottle unless directed by an instructor. Place any unused reagents in the appropriate waste container; **DO NOT** return it to the bottle.
7. Always return chemicals to their appropriate location.
8. NEVER remove or borrow chemicals from another laboratory.
9. If a required chemical is not available or needs to be refilled, notify your instructor.
10. If chemicals are spilled, clear the area and notify your instructor immediately. Faculty will provide guidance on what response action should be taken.
11. In the event of chemical contact with the eyes or skin, **immediately irrigate the contaminated area for a minimum of 15 minutes**. Individuals using the emergency eyewash and/or safety shower should be assisted by an uninjured person to aid in decontamination and to encourage the individual to use the eyewash and/or shower for the full 15 minutes. Clothing that has been in contact with hazardous materials must be removed. Fire blankets and clean lab coats may be used to cover the injured person for warmth and modesty. Report the incident immediately to the instructor and complete the incident / near miss form within 1 day.

1. EQUIPMENT

- V. DO NOT use any equipment until you have been properly instructed in its use.
- VI. DO NOT move ANY piece of equipment without the permission of your instructor.
- VII. DO NOT attempt to alter or repair any piece of equipment. If it is not in proper working order, inform your instructor.
- VIII. Clean all equipment immediately after you have finished using it, and if it was borrowed or checked out, return it immediately.
- IX. Special equipment placed in the classroom or issued by the Service Centers **must be returned to the Stockroom (or instructor if Stockroom is closed) by the end of class** or a fine of \$5.00 will be assessed.

a. SERVICE CENTER

- The Chemistry Service Centers **WILL NOT** issue chemicals or equipment (other than those specifically listed for an experiment, student locker or instructional laboratory) without the consent of the instructor.
- The Service Center staff **WILL NOT** set-up labs after they have been taken down.

• OTHER INCIDENTS

- Injuries not involving chemicals, e.g., burns, cuts must be reported to your instructor. As part of the department's efforts to provide a safe learning environment, the Chemistry Department Safety Committee reviews all incidents in an effort to improve the program.
- Any other incident requiring immediate assistance should also be reported to faculty for appropriate response. In the event of a fire or incident requiring evacuation, faculty will direct students where to evacuate. DIAL 916-278-6900 to reach campus police on any phone. Emergency phones are located in the lobbies of each floor in Sequoia Hall. Fire alarm pull stations are located by the exit of every floor.

****Failure to adhere to these laboratory safety policies will result in your removal from lab. The resulting missed lab can only be made up with instructor approval within the standard makeup time line.**

I HAVE READ AND UNDERSTOOD ALL OF THE ABOVE AND I AGREE TO CONFORM TO ITS CONTENTS.

FOR YOUR RECORDS ONLY

Name: _____ Course: _____
Student ID: _____ Section: _____
Signature: _____ Room: _____
Lab Instructor Signature: _____ Date: _____

Laboratory Regulations

1. Safety is a prime requisite for laboratory work. Eye protection is required at all times unless explicitly stated otherwise. You can not work without appropriate eye protection. A lab apron or coat will prove a good investment for protecting clothing. Learn the location of the safety equipment: fire extinguisher, safety shower, and eye wash fountain. Injuries/accidents should be immediately reported to your instructor.

2. Lab work is to be done on an individual basis unless you are instructed otherwise. Prepare for lab by reading the experiment, preparing tables in your lab notebook (as needed for each experiment) for collecting data, and completing the prelaboratory assignment.

3. Record your results immediately and directly into your notebook. Record observations in detail. ***Do not write on scratch paper. Only write in your laboratory notebook or in the lab manual if indicated in the instructions.***

4. The most productive research demands original work, and this is strongly encouraged. However, for safety reasons this may be done only with the approval and supervision of the instructor. Unauthorized experiments are strictly forbidden.

5. Students are allowed in the laboratories only during regularly scheduled class periods. Make-up labs must be approved by the lab instructor and must be completed within one week of the missed laboratory experiment. Approval is usually only given for medical reasons (that is, if your doctor states you were sick, not if you had a routine appointment). You may not work in another lab without written permission from your laboratory instructor and the laboratory instructor in charge of the other section.

6. Keep your lab area clean. Wipe up in a safe and approved manner spilled materials. Only soluble, harmless materials should be put in the sink, and these should be washed down with plenty of water. Your instructor will advise you when it is permissible to dispose of chemicals in the sink. Unless otherwise instructed insoluble or toxic materials should be put in the containers provided for chemical wastes in the hood. If in doubt, do not pour a substance down the drain; it will soon be carried to a water-treatment plant and possibly pass through into a stream. Heed the warnings on the reagent bottles. If in doubt ask your instructor.

7. Balances and other delicate instruments require special care. Follow carefully the directions for their use.

Laboratory Notebook Requirements

You must have a hard cover, bound notebook that was shown to you in lecture. The laboratory notebook will be collected periodically without prior announcement to ensure you are practicing correct scientific procedures for collecting experimental data. A portion of your laboratory grade will be based on your neatness, completeness, and attention to detail. Failure to bring your notebook to lab with you is not acceptable and you may not be allowed to work.

Table of Contents: You must leave several pages blank at the beginning of your notebook for table of contents. That table will list each experiment that has been done and the page number for which it can be found.

Experimental Notes and Content:

- **Title Page:** Each experiment will start on a new, right hand side of page. It will include the name and number of the experiment.
- **Objective:** Following the cover page, will be a paragraph with the objective of the experiment in your own words. You will most likely need to consult your text book as well as your lab manual for additional information. Please cite any references (see below for more information on this).
- **Experimental Procedures:** You will need to summarize the procedures for the experiment. You do not need to rewrite them, but *summarize* them in a way that you could get through the experiment without your lab manual. **This will require that you read it in depth.**
- **Data Collection Tables:** All data will be signed by your instructor. No signature on data will result in 0 credit. You will need to consult your lab manual for an example of the table you will need to construct in your notebook. This is to be done AHEAD OF TIME. Use a ruler or straight edge to make your tables neat and legible for anyone who would read it (including you!)
- All entries in the notebook **must be in ink.** Record data as you gather them directly into the notebook. **Never record data on loose slips of paper** (e.g. paper towels, scrap paper, etc.) for later transfer to the notebook. Should a correction be necessary, draw a single, light line through the erroneous value and enter the correct value (**example.**) The original value must remain legible (you may later decide to use it). Wherever possible, **tables of data are preferred** to isolate values; in either case, **all values must be clearly labeled** so that your notebook is comprehensible to someone with training comparable to you own. Data should be neatly organized. Record the measurements at the time you make them. If repeated trials are made, list measurements in parallel columns. For example,

Title of Table (Descriptive)

Description of what is being recorded	<u>Trial 1</u> (units)	<u>Trial 2</u> (units)	<u>Trial 3</u> (units)

- **Sample calculations:** Show sample calculations (or all calculations as instructed) below data table. Be sure to include *units*. Units are shown in the columns with their labels. Don't forget your units when showing an example calculation. Since many calculations are repetitive, you can continue to work them out on a separate piece of white paper to include with your report.
- **Observations:** These are a crucial part of your scientific endeavors. Depending on the experiment, some observations can be incorporated into the data table. Other experiments will require a separate section. All experiments have observations, your attention to detail will not only lead to greater success in the laboratory, it will help prepare you for exams and quizzes as well.
- **References:** if you use a particular reference book or website for additional information, please reference it here. It is perfectly acceptable to use reference material other than that of your textbook and lab manual. *It is not only academically dishonest (and often times illegal) to quote a book or website without mention of the origin!*

Prelaboratory Assignment

Prelab assignments are always due at the beginning of the lab period. When you enter the lab, you should tear out your prelab assignment from your lab manual and place it on the instructor's bench at the start of lab.

Failure to complete the prelab assignment will result in your immediate dismissal from lab. In other words, you will not be allowed to perform the experiment nor will you be given any additional time to make up that experiment. This means that if the class is performing an experiment that is given one day to complete, you will receive a 0 for that experiment.

Each prelab assignment is found at the end of the experiment (with the exception of Experiment 1). It consists of a few short answers and/or calculations pertaining to the experiment. Once you have thoroughly read the experiment and completed your notebook requirements, then you should work on the prelab assignment.

Bring your laboratory notebook and laboratory syllabus to each class period unless otherwise stated.

How to Write a Lab Report for Chem 1B

Each experiment that you perform will have its own list of information that needs to be organized into the report you will turn in to your laboratory instructor. This information is found at the end of each experiment in the section labeled Laboratory Report. A general outline of the required sections in your report is shown below. ***Make sure to number each page of your report once it is assembled.***

Title Page # Your name Experiment # Date Partner's name Section # (unknown #) <u>TYPED</u>	Prelab # Signed by instructor. Torn out of lab manual.	Data Pages # From lab notebook that has been signed by lab instructor <u>Photocopy</u>	Results # Tables w/ Results, <u>Hand written</u> calcs under Tables <u>TYPED</u>	Questions, Error Analysis And Conclusions # <u>TYPED</u>
--	---	--	---	--

- **Title page:** Your title page is always to be **typed**. Any additional information listed in the Laboratory Report section for Title Page should also be included. For example, your partner's name (if any; clearly identified! Ex. Partner: Katie Smith), the identity of an unknown along with the unknown number if applicable. Title page should always **include experiment number, title, your name, section number, and date**. Each experiment will require slightly different information on the cover page (see Laboratory Report section of each experiment), but it will always include experiment number, title, your name, section number and date.
- **Pre-Lab Assignment:** Always include your prelab assignment. You can put your prelab with all corrections made at the beginning of the report. Corrections should be made on a separate white piece of paper if needed. As always, please make those corrections easy to read and **reference where those corrections can be found** (by page # in report) if they are placed elsewhere on a separate page.
- **Data Pages:** Photocopy the data pages from your notebook and attach them to your report. The data pages must clearly show your name, page number, the data, and your instructor's signature.
- **Results:** Any tables that are mentioned in the Laboratory Report section should be **computer processed to the extent listed in the Laboratory Report section**. No mistakes! No hand-written values or information in the Tables. There may be an example shown of how that table should look, if not you should create one of your own to display the values or data that is requested. Generally speaking, re-typing of data collected in lab is not necessary unless specifically requested in the Laboratory Report section. Tables should be formatted in a way that the data/values are clearly presented. When typing formulas, you will need to use proper **superscripts** and

subscripts. Your word processor will have a tutorial on this. The appendix section of this lab manual has a general tutorial for an older version of Microsoft Word. This may mean that you have to print them in landscape orientation rather than portrait. It depends on the size of the table, use your judgment and resize columns as necessary. The sample tables below show you an acceptable table with proper sizing and super and subscripts. The second table shows improper column sizing and font formatting.

Acceptable:

K_a (exp) H_3PO_4
1.79×10^{-5}

Not Acceptable:

Ka (exp) H3PO4
1.79 x 10^- 5

Your tables should not be split in half like the example below. Reformat your page size (margins) so that it all appears on one page.

If a table is too large to appear on one page, the column headings should be repeated on the second page where the table continues. *An unacceptable* table is shown below and continues onto the next page without proper column headings:

Acid	pH obs	pH theo	% Diss	K_a exp	K_a theo	p K_a obs	p K_a theo	% Error
------	--------	---------	--------	-----------	------------	-------------	--------------	---------

----- PAGE BREAK -----

HCl	###	###	###	----	large	----	-----	-----
NH ₄ Cl	###	###	###	###	###	###	###	###

Sample Calculations underneath Table: (hand write)

- Calculations:** Many tables that you prepare will be filled with values that you have calculated. See hypothetical table above. You do not need to type calculations. Neatly hand writing that calculation *under the table* is sufficient. Remember that if we can't read it, we can't grade it. **Calculations should always be shown under the table that displays those values. If those calculations cannot be written under the table, clearly list (by giving the page number) where those calculations can be found and number the pages of your report (by hand) so that finding them is clearly mapped out.** You are required to turn in *all* your calculations so that simple math mistakes can be tracked easily and fewer points taken off for those mistakes.
- Questions and Error Analysis:** Many experiments you perform this semester will include a few questions to be answered. These questions are found in the Laboratory Report section and can be torn out of the manual and attached to your report. Make

sure you write in *complete sentences* but they can be short and to the point. Hint: students often misread or misunderstand the question being asked. Always re-read what the question is asking you to answer. A common, yet unacceptable answer is shown on the following page.

Will the calculated value of K be too high or too low if:

1) the original solution was supersaturated?

Student answer: if the solution was supersaturated then that means there was too much of the solid in the solution. Our calculated value of K will be off a lot because we can't account for this amount.

Student did not answer the question that was asked. "Our calculations will be off" is obvious and true for all error analyses yet it does not answer the question asked. Make sure you answer the question you are asked.

- **Conclusions:** *Some* experiments ask you to reflect and make conclusions at the end about what you have done. Conclusions should be typed. A one sentence conclusion is never sufficient however a full page is rarely needed either. Generally a paragraph is all that is needed to accurately describe your conclusions. The Laboratory Report section will indicate whether or not you need a conclusion statement with your report.
- **Thank you:** We know how hard you work in this class, thank you for all your hard work! ☺

Nomenclature of Acids, Bases and Salts Review:

You are expected to know Nomenclature when entering 1B

I. Objective: To review the rules for naming common inorganic acids, bases and salt.

II. Principles: The rules of nomenclature are the rules published by the International Union of Pure and Applied Chemistry (IUPAC). Compounds are still named by these rules; however, others are still named by their historical names (common names). The rules in this section are used by chemists in naming acids, bases and simple salts derived from acids and bases.

I. Binary Compounds.

A binary compound contains only two elements. In general, a binary compound is named by first stating the name of the more electropositive element, followed by the name of the more electronegative element (usually a nonmetal), changing its stem to -ide.

A. Acids: Binary acids in aqueous solution are named differently than in the gas phase. Refer to the examples below to see the differences.

<u>Examples:</u>	<u>Aqueous Solution</u>	<u>Gas Phase</u>
HCl	hydrochloric acid	hydrogen chloride
HBr	hydrobromic acid	hydrogen bromide
H ₂ S	hydrosulfuric acid	hydrogen sulfide
HCN	hydrocyanic acid	hydrogen cyanide
HI	hydroiodic acid	hydrogen iodide

Note: CN⁻ is treated as if it were a single element.

B. Bases: The OH⁻ ion is considered as a single element, therefore all compounds containing OH⁻ are called hydroxides.

Example: Ca(OH) ₂	calcium hydroxide
NaOH	sodium hydroxide
NH ₃	ammonia (common name)

C. Salts: If the metallic element has more than one valence, the oxidation number is designated by a Roman numeral: Fe(II) and Fe(III), for example. Group IA and IIA cations have only one valence; thus there is no need for a Roman numeral.

D. Binary compounds containing two *nonmetallic* elements are usually named in the following manner:

The number of atoms each element in a chemical formula are indicated by numerical prefixes: mono (1), di (2), tri (3), tetra (4), penta (5), hexa (6), hepta (7), octa (8).

Examples: N₂O dinitrogen monoxide
P₂S₅ diphosphorous pentasulfide.

II. Ternary Compounds

Ternary compounds contain three elements.

A. Acids: Most common ternary acids (also called oxyacids) contain hydrogen, oxygen, and another element.

1. The most common acid consisting of this combination of elements is named by adding -ic to the nonmetallic element.

Examples: H_2SO_4 sulfuric acid

H_3BO_3 boric acid

HClO_3 chloric acid

H_2CO_3 carbonic acid

HNO_3 nitric acid

H_3PO_4 phosphoric acid

2. For an acid containing one less oxygen atom than that in (1), the suffix -ic changes from -ic to -ous.

Examples: H_2SO_3 sulfurous acid

HClO_2 chlorous acid

HNO_2 nitrous acid

H_3PO_3 phosphorous acid

3. For acids containing one less oxygen atom than in (2), the suffix remains the same but the prefix hypo- is added.

Example: HClO hypochlorous acid

4. For acids containing one more oxygen atom than the most common acid with a suffix of -ic is named by adding the prefix per- to the name.

Example: HClO_4 perchloric acid

5. A table has been prepared for you on the following page to help summarize the nomenclature rules for naming oxy-acids and oxy-anions. This table is not a complete listing of all ternary compounds but it is a more visual summary of these types of compounds and their corresponding names. The authors of this lab manual urge you to use it and expand it as necessary for your own needs.

Oxy-Anions

Prefix	Suffix						
hypo-	-ite		ClO ⁻	BrO ⁻			
	-ite	NO ₂ ⁻	ClO ₂ ⁻	BrO ₂ ⁻		SO ₃ ²⁻	PO ₃ ³⁻
	-ate	NO ₃ ⁻	ClO ₃ ⁻	BrO ₃ ⁻	CO ₃ ²⁻	SO ₄ ²⁻	PO ₄ ³⁻
per-	-ate		ClO ₄ ⁻	BrO ₄ ⁻			

Notice the shaded row. All of those anions are named using the –ate suffix only. If you memorize those anions only, and know the nomenclature rules when oxygens are added or removed, you will automatically know how to name them correctly without actually having to memorize them. A few examples are shown below.

Anion	Name
NO ₂ ⁻	Nitrite ion
NO ₃ ⁻	Nitrate ion
ClO ₃ ⁻	Chlorate ion
ClO ⁻	Hypochlorite ion
CO ₃ ²⁻	Carbonate ion
SO ₃ ²⁻	Sulfite ion

Oxy-Acids

Prefix	Suffix						
hypo-	-ous		HClO	HBrO			
	-ous	HNO ₂	HClO ₂	HBrO ₂		H ₂ SO ₃	H ₃ PO ₃
	-ic	HNO ₃	HClO ₃	HBrO ₃	H ₂ CO ₃	H ₂ SO ₄	H ₃ PO ₄
per-	-ic		HClO ₄	HBrO ₄			

Examples:

Acid	Name
HNO ₂	Nitrous acid
HNO ₃	Nitric acid
HClO ₃	Chloric acid
HClO	Hypochlorous acid
H ₂ CO ₃	Carbonic acid
H ₂ SO ₃	Sulfurous acid

Remember: Learn the “-ates” for both categories (how many oxygens and the charge of the ion) and you will be able to name all the rest by only having to know the prefix and suffix.

6. **There are six strong acids that you need to memorize.** This list can also be found in your current text book as well. There is an additional strong acid often taught in Chem 1A, HClO_3 , chloric acid. Assume all other acids are weak acids.

Strong acid	Name
HCl	Hydrochloric acid
HBr	Hydrobromic acid
HI	Hydroiodic acid
HNO_3	Nitric acid
HClO_4	Perchloric acid
H_2SO_4	Sulfuric acid

B. Salts:

1. Anions of salts derived from the ic acids, with all hydrogens removed, are named by changing ic to ate.

Example: H_2SO_4 sulfuric acid Na_2SO_4 sodium sulfate.

2. Anions of salts formed from acids containing an ous suffix are named by changing ous to ite.

Example: HClO_2 chlorous acid NaClO_2 sodium chlorite

3. Anions of salts of hypo ...ous acids retain the prefix hypo but ous is changed to ite.

Example: HClO hypochlorous acid NaClO sodium hypochlorite

4. Anions of salts from a per...ic acid retain the prefix per and ate is substituted for ic.

Example: HClO_4 perchloric acid KClO_4 potassium perchlorate.

5. Some salts contains anions that contain hydrogen, e.g. KHS and NaHSO_4 . These anions are derived from acids which are not completely neutralized. The name of the anion is formed by adding the word “hydrogen” with a numerical prefix where necessary, to indicate the number of replaceable hydrogens. The word hydrogen occurs first.

Examples: NaHSO_4 sodium hydrogen sulfate
 $\text{Al}(\text{HSO}_4)_3$ aluminum hydrogen sulfate
 NaH_2PO_4 sodium dihydrogen phosphate
 $\text{Ca}(\text{H}_2\text{PO}_4)_2$ calcium dihydrogen phosphate

The prefix “mono” is not necessary to indicate one hydrogen.

Appendix 1 has many practice problems for you to work.

Experiment 1

Chemical Reactions and Net Ionic Equations

I. Objective:

To predict the products of some displacement reactions and write net ionic equations. Note-the (aq) has been eliminated from all equations below while (s), (l) and (g) have been used to represent phases. *When you write chemical reactions in your lab reports you must show all phases including (aq).*

II. Chemical Principles:

A. Reaction Types.

1. Combination. This reaction type involves the combining of elements and/or compounds to form a new compound.

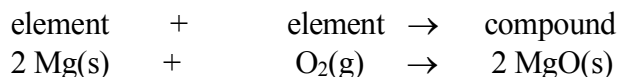

2. Decomposition. This reaction type involves the splitting apart of a single compound to form new compounds or elements.

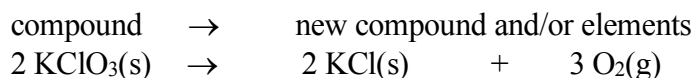

3. Single Replacement. This reaction type involves an element displacing another element or ion in a compound, or a chemical compound displacing an element or ion from another compound.

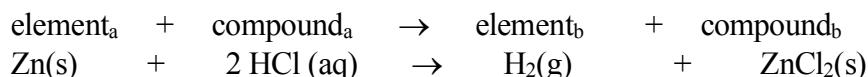

4. Double Displacement (Metathesis). This reaction type involves the exchange of elements or ions in two compounds. **Double displacement reactions will be the focus of this experiment.**

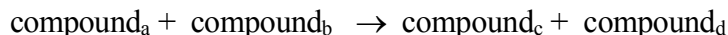

a. precipitation:

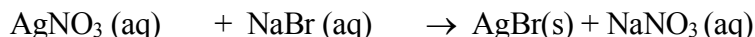

b. dissolution

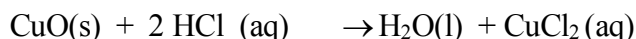

c. neutralization

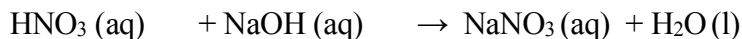

d. gas forming



e. Complex ion formation (not technically a double-displacement reaction)

Transition metals are good electron acceptors and are capable of complexing whole neutral molecules (and some anions) to form a *new complex ion*. Complex ion reactions are common in qualitative analysis. An example is shown below.

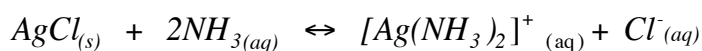

To be able to predict the products of these reactions, you must know the identity and properties of ionic compounds, acids and bases, and molecular species.

B. Predicting Products of Displacement Reactions and Writing Net Ionic Equations.

Strong Acids. All strong acids completely dissociate in water, for example:

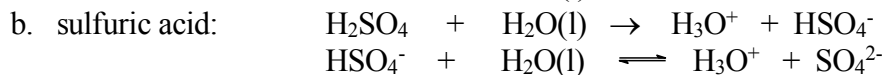
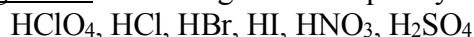

The first ionization step for sulfuric acid is 100%, however the second step is an equilibrium situation and ionization is only partial.

Note: Molecules of strong acids such as HClO_4 and H_2SO_4 do not exist in solution because we treat them as ionizing 100% that is as strong electrolytes. $\text{H}^+(\text{aq})$ can be written in place of H_3O^+ , the hydronium ion.

Weak Acids. These acids react only slightly with water to produce the hydronium ion. They, however, will react completely with a strong base. Please note (aq) symbol is omitted.

Acid	Reaction	Extent of Reaction
acetic acid	$\text{HC}_2\text{H}_3\text{O}_2 + \text{H}_2\text{O}(\text{l}) \rightleftharpoons \text{H}_3\text{O}^+ + \text{C}_2\text{H}_3\text{O}_2^-$	0.42%
carbonic acid	$\text{H}_2\text{CO}_3 + \text{H}_2\text{O}(\text{l}) \rightleftharpoons \text{H}_3\text{O}^+ + \text{HCO}_3^-$ $\text{HCO}_3^- + \text{H}_2\text{O}(\text{l}) \rightleftharpoons \text{H}_3\text{O}^+ + \text{CO}_3^{2-}$	0.065%
ammonium ion	$\text{NH}_4^+ + \text{H}_2\text{O}(\text{l}) \rightleftharpoons \text{H}_3\text{O}^+ + \text{NH}_3$	0.0024%

* 1.0 M solution

Strong bases: dissociate completely in water.

- Soluble metal hydroxides. $\text{MOH} \rightarrow \text{M}^+ + \text{OH}^-$
- Insoluble metal hydroxides. All insoluble metal hydroxide dissolve to a very limited extent to form metal ions and hydroxide ions. Because the dissolved form of the insoluble metal hydroxide dissociates completely it is considered a strong electrolyte and thus it is a strong base. The OH^- ion is the strongest base that exists in water. *For example, calcium hydroxide is said to be insoluble, but the reality is that some calcium and hydroxide ions exist in solution and therefore the solution is basic.* $\text{Ca}(\text{OH})_2(\text{s}) \rightleftharpoons \text{Ca}^{2+}(\text{aq}) + 2 \text{OH}^-(\text{aq})$

Moderately soluble bases are strong bases because what does dissolve, dissociates 100%.

Weak bases: These substances react slightly with water to produce OH^- and are weak electrolytes. Please note (aq) symbol is omitted.

Base	Reaction	Extent of reaction*
ammonia	$\text{NH}_3 + \text{H}_2\text{O} \rightleftharpoons \text{NH}_4^+ + \text{OH}^-$	0.42%
acetate ion	$\text{C}_2\text{H}_3\text{O}_2^- + \text{H}_2\text{O} \rightleftharpoons \text{HC}_2\text{H}_3\text{O}_2 + \text{OH}^-$	0.0024%
carbonate ion	$\text{CO}_3^{2-} + \text{H}_2\text{O} \rightleftharpoons \text{HCO}_3^- + \text{OH}^-$	1.3%
fluoride ion	$\text{F}^- + \text{H}_2\text{O} \rightleftharpoons \text{HF} + \text{OH}^-$	0.00053%

* 1.0 M solution

Salts: Salts contain a metal ion and a nonmetal or polyatomic anion. Salts can be formed by a neutralization reaction: a reaction between an acid and a base producing a salt and water. For example:

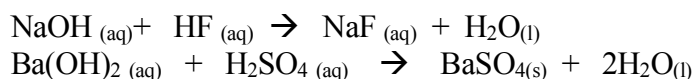

Some salts, such as sodium fluoride, are very soluble in water, therefore a change is not observed upon reaction. However, some salts such as barium sulfate are quite insoluble in water and a precipitate will be observed when formed as a product in a reaction.

Strong and Weak Electrolytes:

You need to know which substances are strong and weak electrolytes and which substances are soluble and insoluble and what is the limit of solubility of a compound in aqueous solution. Some rules are given in the following Tables.

Table II. Strong and Weak Electrolytes

<p>1. Strong electrolytes (e.g. NaCl): Dissociate completely (100%) when dissolved in water. Strong acids, strong bases and many salts* are strong electrolytes. (There are a few exceptions, the halides and cyanides of Hg_2^{2+}, Cd^{2+}, Zn^{2+}, and Ag^+ are not strong electrolytes.)</p>
<p>2. Weak electrolytes (e.g. Acetic Acid): Do not dissociate completely (<100%) when dissolved in water. Only a few ions will be produced in solution. Weak acids, weak bases and many organic compounds are weak electrolytes.</p>
<p>3. Nonelectrolytes (e.g. Sugar): Do not dissociate into ions when dissolved in water. Pure water and many organic compounds are nonelectrolytes. These are normally molecular compounds.</p>

* Note! The terms strong electrolyte and solubility are not equivalent. Why? Because many salts are insoluble in water, however, what limited quantity does dissolve in water, dissociates 100%. Therefore, the salt, even if insoluble, is a strong electrolyte.

Table III. Solubility Rules for Salts in Water from your textbook (Chemistry by Tro). Note the important exceptions and considerations listed beneath the table.

TABLE 4.1 Solubility Rules for Ionic Compounds in Water	
Compounds Containing the Following Ions Are Generally Soluble	Exceptions
Li^+ , Na^+ , K^+ , and NH_4^+	None
NO_3^- and $C_2H_3O_2^-$	None
Cl^- , Br^- , and I^-	When these ions pair with Ag^+ , Hg_2^{2+} or Pb^{2+} , the resulting compounds are insoluble.
SO_4^{2-}	When SO_4^{2-} pairs with Sr^{2+} , Ba^{2+} , Pb^{2+} , Ag^+ , or Ca^{2+} , the resulting compound is insoluble.
Compounds Containing the Following Ions Are Generally Insoluble	Exceptions
OH^- and S^{2-}	When these ions pair with Li^+ , Na^+ , K^+ , or NH_4^+ , the resulting compounds are soluble.
	When S^{2-} pairs with Ca^{2+} , Sr^{2+} , or Ba^{2+} , the resulting compound is soluble.
	When OH^- pairs with Ca^{2+} , Sr^{2+} , or Ba^{2+} , the resulting compound is slightly soluble.
CO_3^{2-} and PO_4^{3-}	When these ions pair with Li^+ , Na^+ , K^+ , or NH_4^+ , the resulting compounds are soluble.

**All acetates are soluble, but note that $AgC_2H_3O_2$ is slightly soluble*

**All sulfates are soluble except when paired with Sr^{2+} , Ba^{2+} , and Pb^{2+} . Note that $CaSO_4$ and Ag_2SO_4 are slightly soluble!*

**All chromates (CrO_4^{2-} and $Cr_2O_7^{2-}$) are insoluble except those that contain Li^+ , Na^+ , K^+ and NH_4^+ . All oxides (O^{2-}) are quite insoluble*

Solubility is defined as the maximum amount of substance that dissolves in a given amount of solvent at a given temperature . The solubility limit of many compounds can be found in the Handbook of Chemistry and Physics.

C. Rules for Writing Net Ionic Equations

1. Write the overall balanced “molecular” equation.
2. Rewrite the molecular equation so that only soluble, strong electrolytes are separated into their ions.
3. Eliminate all species common to the reactants and products (spectator ions).
4. The resultant equation is the net ionic equation.
5. There is no net ionic equation if there is no reaction.

D. Application of Net Ionic Equation Rules.

Example 1: (Production of a solid)

Predict the outcome of the following reaction and write the net ionic equation,



- a. Complete the equation by carrying out a double replacement reaction (exchange partners)

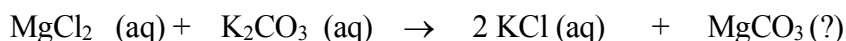

- b. Use rules 1.A - 6.A, 1.B - 3.B, and 1.C - 7.C to determine if a reaction occurred. According to 6.C, MgCO_3 is insoluble and will precipitate, write a (s) next to the compound. According to 1.A, a reaction occurs.

- c. Write the molecular equation and then apply rules given above to separate strong electrolytes into their ion forms and identify magnesium carbonate as an insoluble substance.

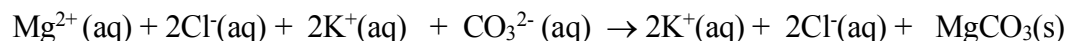
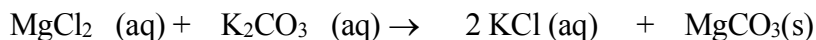

- d. Eliminate ions common to reactants and products and the result is the net ionic equation:

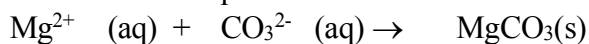

Example 2: (Production of a Gas)

Predict the outcome of the reaction of hydrochloric acid with $\text{MgCO}_3(\text{s})$.

- a. Complete the double displacement reaction.

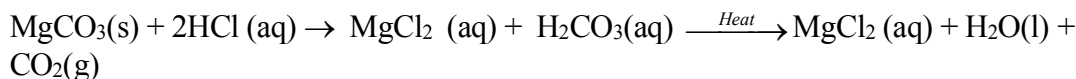

Note: H_2CO_3 is a weak acid that in the presence of heat decomposes to $\text{H}_2\text{O}(\text{l})$ and $\text{CO}_2(\text{g})$. We normally show carbonic acid in the decomposed form.

- b. Use the rules to determine if a reaction has occurred. A reaction occurs because carbonic acid forms and it is a weak acid and weak electrolyte.

- c. Separate the soluble and strong electrolytes into ions.



- d. Eliminate the common ions and the result is the net ionic equation.

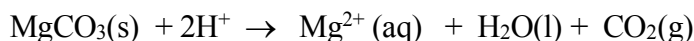

Example 3: (No observed reaction)

Predict the result of the following reaction and write the net ionic equation.

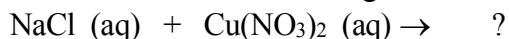

- a. Complete the equation by carrying out a double displacement reaction.

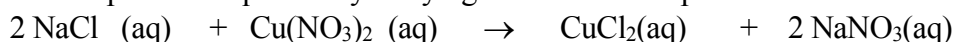

- b. Use the rules to determine if a reaction has occurred.

Both CuCl_2 (5.C) and NaNO_3 (2.C) are soluble and strong electrolytes. Thus no reaction can occur as the requirements of Rules 1.A - 5.A are not met.

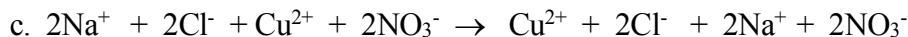

- d. All the ions cancel and thus there is no net ionic equation.

Example 4: (Acid - base reaction)

Predict the outcome of the following reaction and write the net ionic equation.

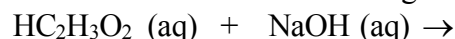

- a. Complete the balanced equation by carrying out a double displacement reaction.

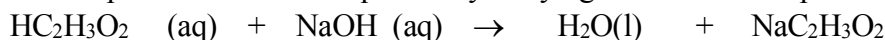

- b. Has a reaction occurred?

Water is a new covalent substance (2.A), so a reaction has occurred.

c. Separate all strong electrolytes into ions.

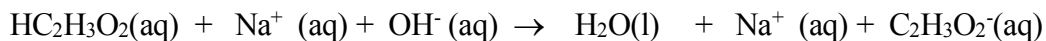

Note: $\text{HC}_2\text{H}_3\text{O}_2$ is a weak electrolyte and therefore it is written as a molecule.

d. Eliminate the spectator ion and the result is the net ionic equation.

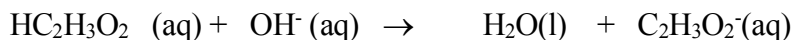

Example 5 (Acid-base reaction):

Predict the outcome of the following reaction and write the net ionic equation.

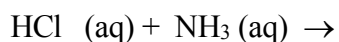

a. Complete the equation by carrying out a single displacement reaction.

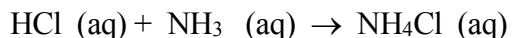

b. This is a strong acid reacting with a weak base. A weaker acid (a new covalent substance), H_2O , is produced therefore a reaction occurs.

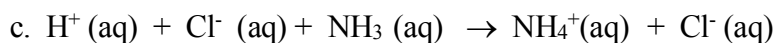

d. Eliminating chloride ion, the spectator ion, gives the net ionic equation.

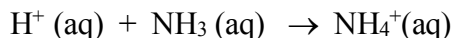

The following Data Tables I-III will be used to record your laboratory observations and will be torn out and included with your final laboratory report.

Experimental Procedure for Table I:

- Slowly add, with a spatula, a very *tiny* amount (less than the size of a grain of rice) of the compounds listed in **Table I** to about 1 mL (approximately 20 drops) of water in a test tube. Note any change in the solubility. Do not add too much compound to the water as the volume is small and only a small amount of compound is required. Add extra water if needed.
- Note! You will test the solubility of compounds 1, 2, 4, 5, and 7 in 6M HNO₃ after you have tested their solubility in water. Just add 1mL of 6M HNO₃ to see if the solid dissolves.

Waste Disposal: Your laboratory instructor has already shown you where the waste disposal bottles are in the back fume hood. The following compounds need to be placed in the correct waste bottle for safety reasons as well to reduce fees incurred by cross contamination.

The following compounds need to be disposed of in the Metal Salts container:

- BaSO₄, Ca(NO₃)₂, Ca₃(PO₄)₂, (NH₄)₂SO₄, PbCO₃, AgC₂H₃O₂, Hg₂Cl₂,
- Cu₂O, NaHSO₄, KI, BaCl.

Use the Organic Waste container for the following compounds:

- C₆H₁₂O₆
- benzoic acid, C₆H₅COOH

Table I Solubility of Compounds in Water

	Solid compound	Lab Results: Solubility in H₂O	Lab Results: Solubility in HNO₃
1	BaSO ₄		
2	Ca ₃ (PO ₄) ₂		
3	(NH ₄) ₂ SO ₄		-----
4	PbCO ₃		
5	AgC ₂ H ₃ O ₂		
6	Hg ₂ Cl ₂		-----
7	Cu ₂ O		
8	C ₆ H ₁₂ O ₆		-----
9	C ₆ H ₅ COOH		-----
10	BaCl ₂		-----

Experimental Procedure for Table II: Place each compound in the first column in a well of a spot plate. If a compound is a solid and not a liquid, add a small amount of water to it and stir. For all solutions, use 0.1 M provided in lab. Use a conductivity device to determine if the substance is conducting or not. Record the relative brightness of the light or absence of light. A bright light only indicates more ions are in solution compared to a dim light, not whether it is a strong or weak electrolyte. The concentration of ions must be known to make a more definitive conclusion. The absence of a light indicates that ions are not present. Only the ends of the two copper probes of the device should be in the solution. On the back of the conductivity device is a guide for you to use.

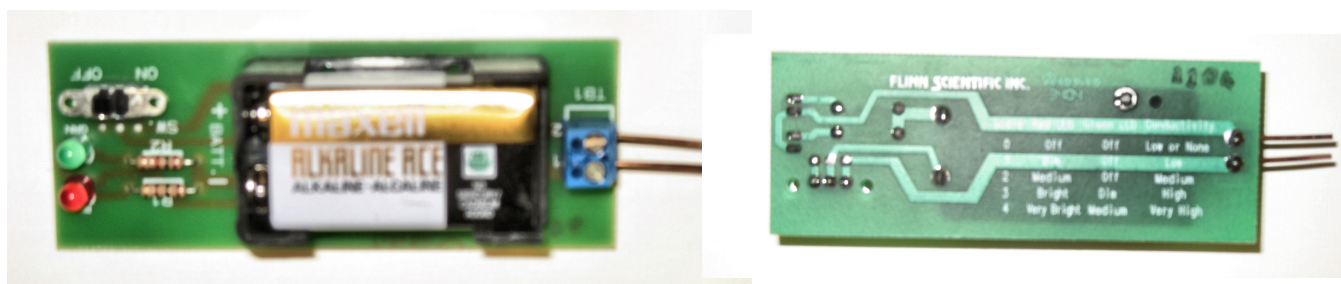

Table II: Electrolytes

	Compound	Lab Results from Conductivity device
1	HNO ₃	
2	HC ₂ H ₃ O ₂	
3	NH ₃	
4	NaOH	
5	Ca(OH) ₂	
6	K ₂ CO ₃	
7	Cu(NO ₃) ₂	
8	NiCl ₂	
9	Zn(NO ₃) ₂	
10	C ₂ H ₅ OH (ethanol)	

Experimental Procedure for Table III Add approximately 2-3 drops of each pair of reactants in the first column to a test tube. Use 0.1 M solutions for all reactants except when noted differently. Record your observations in column Experimental Observations. Be sure to note the formation of a precipitate, any color change, color of precipitate, evolution of a gas, etc. **For a "b" reaction**, add 6 drops of the indicated reagent to the precipitate that is left in the well plate to determine if it dissolves. Record your observations in column Experimental Observations.

Table III: Double Displacement Reactions

	Reactants	Experimental Observations
1a	$\text{Ba}(\text{NO}_3)_{2(\text{aq})} + \text{K}_2\text{SO}_{4(\text{aq})}$	
1b	$\text{BaSO}_{4(\text{s})} + \text{HCl} (12\text{M})$	
2a	$\text{NiCl}_{2(\text{aq})} + \text{Na}_2\text{CO}_{3(\text{aq})}$	
2b	$\text{NiCO}_{3(\text{s})} + \text{HCl} (12\text{M})$	
3a	$\text{CoCl}_{2(\text{aq})} + \text{KOH} (6\text{M})$	
3b	$\text{Co}(\text{OH})_{2(\text{s})} + \text{HCl} (12\text{M})$	
4a	$\text{Na}_3\text{PO}_{4(\text{aq})} + \text{ZnSO}_{4(\text{aq})}$	
4b	$\text{Zn}_3(\text{PO}_4)_{2(\text{s})} + \text{HCl} (12\text{M})$	
5a	$\text{Na}_2\text{S}_{(\text{aq})} + \text{Cu}(\text{NO}_3)_{2(\text{aq})}$	
5b	$\text{CuS}_{(\text{s})} + \text{HCl} (12\text{M})$	
6	$\text{Na}_2\text{CO}_3(\text{sat'd}) + \text{HCl} (12 \text{ M})$	
7	$\text{Cu}(\text{NO}_3)_{2(\text{aq})} + \text{NH}_3 (12\text{M})$	
8a	$\text{AgNO}_{3(\text{aq})} + \text{NaCl}_{(\text{aq})}$	
8b	$\text{AgCl}_{(\text{s})} + \text{NH}_3 (12\text{M})$	
9	$\text{CaCl}_{2(\text{aq})} + \text{NH}_3 (12\text{M})$	
10	$\text{NH}_4\text{Cl}_{(\text{aq})} + \text{NaOH}_{(\text{aq})}$	

IV. Laboratory Report:

1. Typed Title page.
2. Prelab Tables Ia,Ib,Ic and II and III from lab manual containing your instructor's signature.
3. Data Tables I, II, III (torn out) from your manual signed by your instructor.
4. Once your report has been assembled, write the page number in the upper right corners of each page. An example layout is shown below.

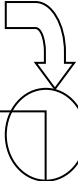

Title Page Your name Chem 1B Section # Date Experiment #	Prelab Table Ia (Signed prelab from manual)	Prelab Table Ib (signed prelab from manual)	Prelab Table Ic (signed prelab from manual)
Prelab Table II (signed prelab from manual)	Prelab Table III (Signed prelab from manual)	Prelab Corrections If Needed (may be multiple pages depending on corrections needed)	Data Table I Solubility of Compounds in Water (Signed data from manual)
Data Table II Electrolytes (Signed data from manual)	Data Table III Double Displacement Reactions (Signed data page from manual)		

This page is intentionally left blank

Chemistry 1B
 Experiment 1
 Prelab Assignment

Name: _____

Section #: _____

Prelab: Due the first day of the experiment. You will **NOT** be allowed to perform the experiment if the prelaboratory assignment is not completed when you come to lab. You will **tear these out at the beginning of the lab period and stack them on the instructor's bench** in the front.

- **Read the Introduction.**
- If you do not have the lab manual, print out Exp 1 from your instructor's website.
- The Prelab consists of completing ALL of the Tables.

Instructor Use Only: _____

Prelab Table Ia: Using the solubility rules, write in the predicted results for each pair of ions. Write the formula of the compound that would result for each pair and indicate **I** for *insoluble*, or **S** for *soluble*, or **SS** for *slightly soluble*. Two examples have been done.

Prelab Table Ia : Prediction of Solubility of Salts in water.

	Cl ⁻	Br ⁻	I ⁻	SO ₄ ²⁻	PO ₄ ³⁻	OH ⁻	CO ₃ ²⁻	C ₂ H ₃ O ₂ ⁻	S ²⁻	CrO ₄ ²⁻
Na ⁺	NaCl S									
K ⁺										
NH ₄ ⁺										
Ca ²⁺										
Mg ²⁺										
Ba ²⁺										
Cr ³⁺										
Fe ²⁺										
Co ²⁺										
Ni ²⁺							NiCO ₃ I			
Cu ²⁺										
Ag ⁺										
Pb ²⁺										

Prelab Table Ib Solubility of Compounds in Water

	Solid compound	Name of compound	Primary species in H₂O	Predicted Solubility in H₂O	Solubility in 100mL H₂O from CRC Handbook	Predicted Solubility in HNO₃ (Write a Net Ionic Equation to predict this)
1	BaSO ₄	Barium sulfate	BaSO ₄ (s)	Insoluble	0.31mg	
2	Ca ₃ (PO ₄) ₂					
3	(NH ₄) ₂ SO ₄					-----
4	PbCO ₃					
5	AgC ₂ H ₃ O ₂					
6	Hg ₂ Cl ₂	Mercury(I) chloride	Hg ₂ Cl ₂ (s)	Insoluble	0.4 mg	-----
7	Cu ₂ O					
8	C ₆ H ₁₂ O ₆	sucrose				-----
9	C ₆ H ₅ COOH	Benzoic acid				-----
10	BaCl ₂	Barium chloride	Ba ²⁺ and 2Cl ⁻ ions	Soluble	37.0 g	-----

*Note: For the experiment, you will test the solubility of all compounds in water. You will test the solubility of compounds 1, 2, 4, 5, and 7 in HNO₃ only. **Write Net Ionic Equations for the compounds for which you test their solubility in HNO₃ (1, 2, 4, 5, and 7). Do this on the next page in space provided.***

Prelab Table Ic Net Ionic Reactions for Selected Salts (1,2,4,5,7).

Reactions:	Corrections if needed: For lab report
1.	1.
2.	2.
4.	4.
5.	5.
7.	7.

Prelab Table II

Fill in all columns. This, along with all other tables is due at the beginning of the lab period. Refer to your text and lab manual (part of your prelab reading assignment) for a review of electrolytes.

Prelab Table II: Electrolytes

	Compound	Primary Species in H₂O	Acid, Base, Salt, Organic	Strong, Weak, Nonelectrolyte
1	HNO ₃			
2	HC ₂ H ₃ O ₂	HC ₂ H ₃ O ₂	Weak acid	Weak electrolyte
3	NH ₃			
4	NaOH			
5	Ca(OH) ₂			
6	K ₂ CO ₃	2K ⁺ , CO ₃ ²⁻	Salt and weak base (CO ₃ ²⁻)	Strong electrolyte
7	Cu(NO ₃) ₂			
8	NiCl ₂			
9	Zn(NO ₃) ₂			
10	C ₂ H ₅ OH (ethanol)			

Prelab for Table III:

Write the 3 steps for the net ionic equation for the reactions listed below. First one is done for you. Assume all reactants are aqueous 0.1 M solutions except where other phases and concentrations are noted. The molarities that are shown are for experimental purposes and do not affect the net ionic equations. You will tear this out along with the other tables and place on the instructor's bench.

Remember if I can't read it, I won't grade it. Write neatly please

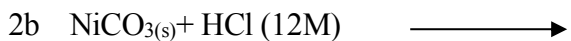
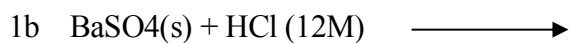
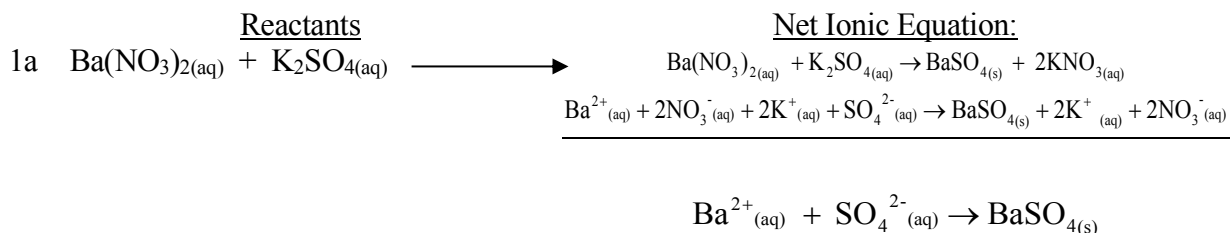

Reactants

Net Ionic Equation:

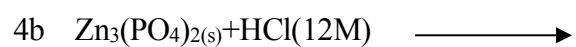
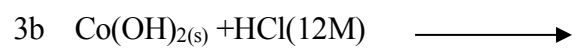
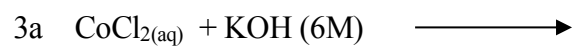

Reactants

Net Ionic Equation:

